

Bladeless Microcreper



MICREX CORPORATION

17 INDUSTRIAL ROAD
WALPOLE, MA 02081 USA
508.660.1900, 800.660.1915
Fax: 508.660.1818
e-mail: micrex@micrex.com
www.micrex.com

Textiles / Paper / Nonwovens / Healthcare / Service
Softness, Bulk, Shrinkage Control, Stretch, Extensibility,
Drape, Hand, Decorative Effects, Absorbency

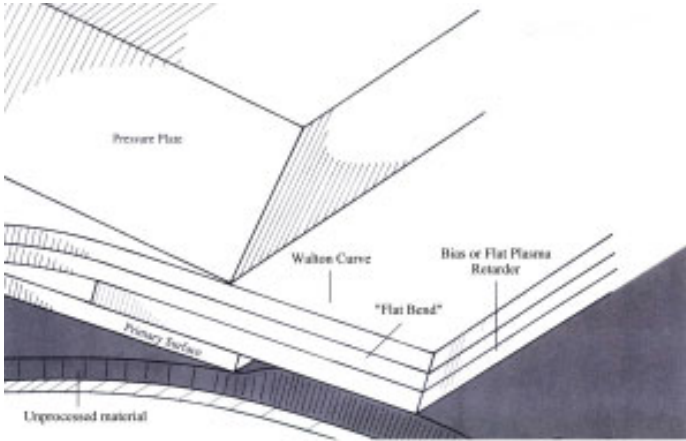

compaction and crepe profile can be obtained - depending upon the desired result and the characteristics of the material being treated.

There are numerous advantages to The Micrex Process. Speeds of up to 300 meters per minute are obtainable on some substrates. Being a mechanical process, there are no dangerous chemicals to handle. Consumable parts usage is low with parts costing less than 3/10 of a cent (\$0.003) per square meter of material processed.

Micrex/Microcrepers are available in widths from 42" (1067 mm) to 124" (3150 mm). Micrex can supply just the Microcreper itself or a complete turn-key system.

Bladeless Cavity

The Micrex Process is a unique, uncomplicated mechanical technology to impart functional (stretch, extensibility, bulk) and esthetic (softness, drape, hand) qualities to a wide range of web structures. There are five configurations of the Micrex/Microcreper: Comb Roll, Rigid Retarder, Bladeless, Flat Blade and Two Roll.

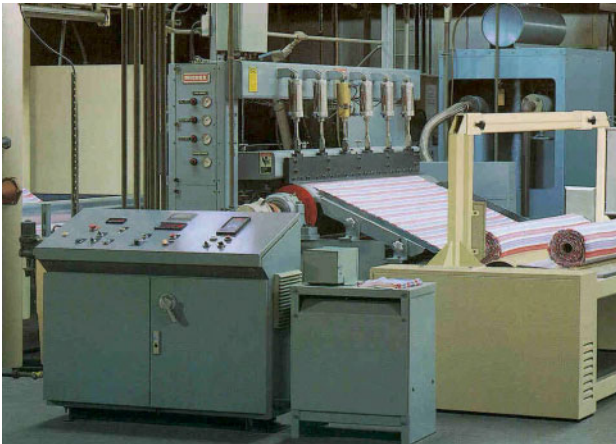
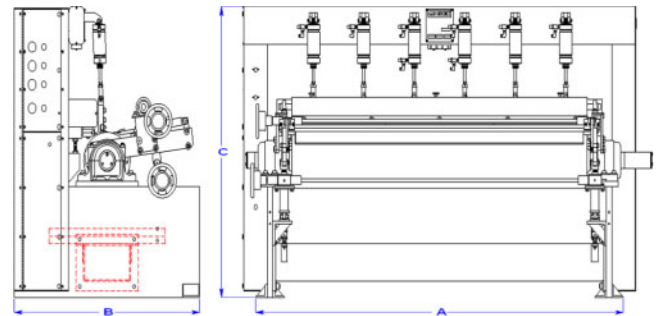

76" (1930 MM) Micrex system shrinkproofing knits

Roll Face & Model	Machine Width (A)	Machine Length (B)	Machine Height (C)	Working Width	Weight
1067 mm (42")	1450 mm	1219 mm	1727 mm	965 mm	1820 kg
1626 mm (64")	1956 mm	1219 mm	1727 mm	1524 mm	2500 kg
1930 mm (76")	2261 mm	1219 mm	1727 mm	1828 mm	2720 kg
2235 mm (88")	2692 mm	1219 mm	1727 mm	2134 mm	3000 kg
2235 mm (88")	2692 mm	1422 mm	1829 mm	2134 mm	4080 kg
2540 mm (100")	2997 mm	1422 mm	1829 mm	2438 mm	4540 kg
2235 mm (124")	3607 mm	1422 mm	1829 mm	3048 mm	5910 kg

The Bladeless configuration is widely used to soften light weight nonwovens, bulk gauze, and a wide range of shrinkproofing applications. The operation is a simple mechanical technology with the management of geometry and force being precisely controlled. By adjustment of the controls, varying amounts of residual

To evaluate the benefits of the Micrex/Comb Roll on your materials, contact Micrex directly. Micrex will arrange a free trial using your materials at our lab.

Note: Not all materials can be processed successfully. Micrex can only represent performance on materials where trials have been performed on a commercial scale.

US and Foreign Patents and Patents Pending. Micrex is a registered trademark.